

## Pipeline Hazards

4-4-2003

---

---

---

---

---

---

---

## Opening Discussion

- What did we talk about last class?
- Have you seen anything interesting in the news?
- Do pipeline hazards produce a fundamental change in control? If so, what is it?

---

---

---

---

---

---

---

## Example Data Hazard with Forwarding

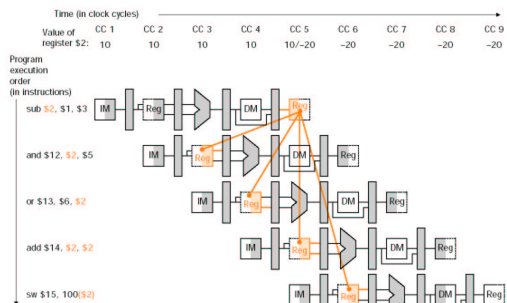

---

---

---

---

---

---

---

## Fixing the Data Hazard with Forwarding

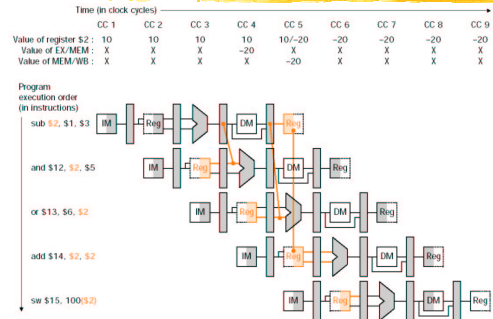

---

---

---

---

---

---

---

---

---

---

## Simple Pipeline with Forwarding

No longer a "hazard".

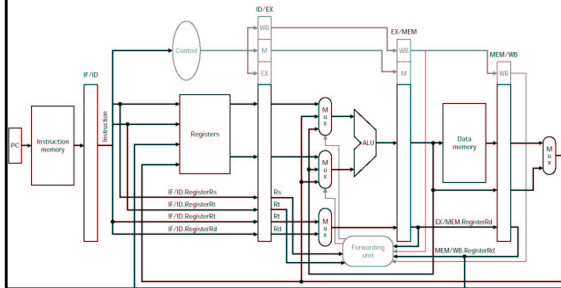

---

---

---

---

---

---

---

---

---

---

## Example Data Hazard that Stalls

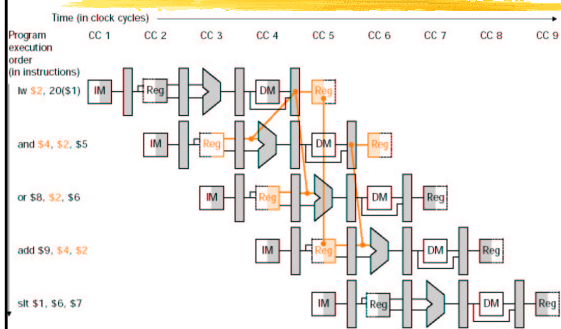

---

---

---

---

---

---

---

---

---

---

## Fixing the Execution

Need to stall one cycle to fix this.

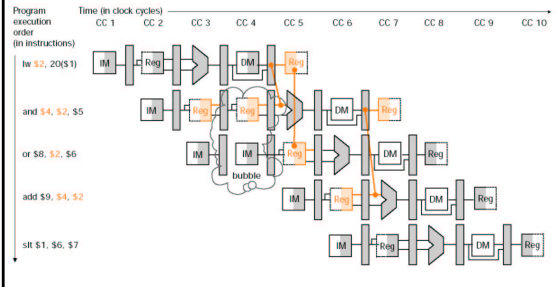

---

---

---

---

---

---

---

---

---

---

---

---

## New Datapath

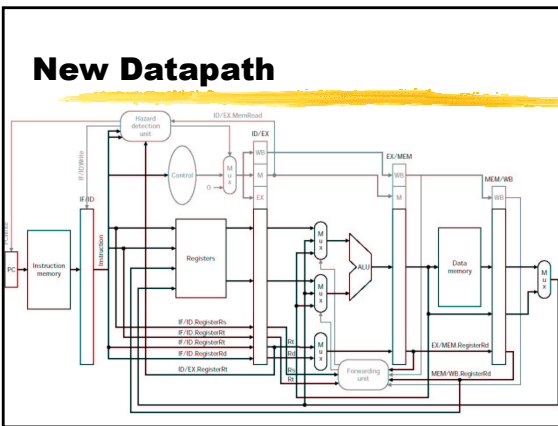

---

---

---

---

---

---

---

---

---

---

---

---

## Example Branch Hazard

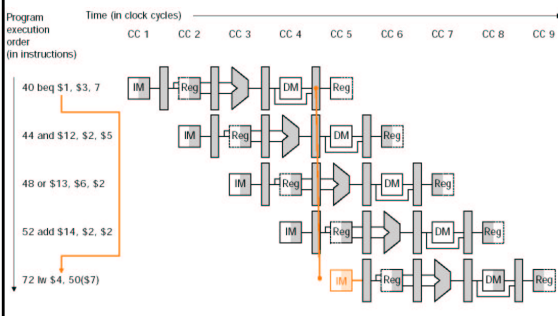

---

---

---

---

---

---

---

---

---

---

---

---

